

FEATURES

- High short circuit capability, self limiting short circuit current
- $V_{CE(sat)}$ with positive temperature coefficient
- Fast switching and short tail current
- Free wheeling diodes with fast and soft reverse recovery
- Low switching losses

APPLICATIONS

- High frequency switching application
- Medical applications
- Motion/servo control
- UPS systems



INVERTER SECTOR

ABSOLUTE MAXIMUM RATINGS

$T_C=25^{\circ}\text{C}$ unless otherwise specified

Symbol	Parameter	Test Conditions	Values	Unit
IGBT				
V_{CES}	Collector - Emitter Voltage	$T_{vj}=25^{\circ}\text{C}$	600	V
V_{GES}	Gate - Emitter Voltage		± 20	V
I_c	DC Collector Current	$T_C=25^{\circ}\text{C}$	550	A
		$T_C=50^{\circ}\text{C}$	450	A
I_{CM}	Repetitive Peak Collector Current	$t_p=1\text{ms}$	900	A
P_{tot}	Power Dissipation Per IGBT		1154	W
Diode				
V_{RRM}	Repetitive Reverse Voltage	$T_{vj}=25^{\circ}\text{C}$	600	V
$I_{F(AV)}$	Average Forward Current	$T_C=25^{\circ}\text{C}$	550	A
		$T_C=50^{\circ}\text{C}$	450	A
I_{FRM}	Repetitive Peak Forward Current	$t_p=1\text{ms}$	900	A
I^2t		$T_{vj}=125^{\circ}\text{C}, t=10\text{ms}, V_R=0\text{V}$	12500	A^2s

INVERTER SECTOR

ELECTRICAL AND THERMAL CHARACTERISTICS

T_C=25°C unless otherwise specified

Symbol	Parameter	Test Conditions	Min.	Typ.	Max.	Unit
IGBT						
V _{GE(th)}	Gate - Emitter Threshold Voltage	V _{CE} =V _{GE} , I _C =7.2mA	4.9	5.8	6.5	V
V _{CE(sat)}	Collector - Emitter Saturation Voltage	I _C =450A, V _{GE} =15V, T _{Vj} =25°C		1.45		V
		I _C =450A, V _{GE} =15V, T _{Vj} =125°C		1.6		V
I _{ces}	Collector Leakage Current	V _{CE} =600V, V _{GE} =0V, T _{Vj} =25°C			1	mA
		V _{CE} =600V, V _{GE} =0V, T _{Vj} =125°C			5	mA
I _{GES}	Gate Leakage Current	V _{CE} =0V, V _{GE} ± 15V, T _{Vj} =125°C	-400		400	nA
R _{Gint}	Integrated Gate Resistor			0.67		Ω
Q _{ge}	Gate Charge	V _{CE} =300V, I _C =450A, V _{GE} = ± 15V		4.8		μC
C _{ies}	Input Capacitance	V _{CE} =25V, V _{GE} =0V, f =1MHz		28		nF
C _{res}	Reverse Transfer Capacitance				0.85	
t _{d(on)}	Turn - on Delay Time	V _{CC} =300V, I _C =450A, T _{Vj} =25°C		75		ns
		R _G =1.5 Ω, T _{Vj} =125°C		80		ns
t _r	Rise Time	V _{GE} = ± 15V, T _{Vj} =25°C		65		ns
		Inductive Load T _{Vj} =125°C		70		ns
t _{d(off)}	Turn - off Delay Time	V _{CC} =300V, I _C =450A, T _{Vj} =25°C		470		ns
		R _G =1.5 Ω, T _{Vj} =125°C		500		ns
t _f	Fall Time	V _{GE} = ± 15V, T _{Vj} =25°C		70		ns
		Inductive Load T _{Vj} =125°C		95		ns
E _{on}	Turn - on Energy	V _{CC} =300V, I _C =450A, T _{Vj} =25°C		4.95		mJ
		R _G =1.5 Ω, T _{Vj} =125°C		6.30		mJ
E _{off}	Turn - off Energy	V _{GE} = ± 15V, T _{Vj} =25°C		15.0		mJ
		Inductive Load T _{Vj} =125°C		17.5		mJ
I _{sc}	Short Circuit Current	t _{psc} ≤ 6μS, V _{GE} =15V T _{Vj} =125°C, V _{CC} =360V		2250		A
R _{thJC}	Junction-to-Case Thermal Resistance (Per IGBT)				0.13	K /W
Diode						
V _F	Forward Voltage	I _F =450A, V _{GE} =0V, T _{Vj} =25°C		1.55		V
		I _F =450A, V _{GE} =0V, T _{Vj} =125°C		1.5		V
t _{rr}	Reverse Recovery Time	I _F =450A, V _R =300V		300		ns
I _{RRM}	Max. Reverse Recovery Current	di _F /dt=-5900A/μs		290		A
E _{rec}	Reverse Recovery Charge	T _{Vj} =125°C		7.5		mJ
R _{thJCD}	Junction-to-Case Thermal Resistance (Per Diode)				0.24	K /W

MMG450WB060B6EN

NTC CHARACTERISTIC VALUES

$T_C=25^{\circ}\text{C}$ unless otherwise specified

Symbol	Parameter	Test Conditions	Min.	Typ.	Max.	Unit
R_{25}	Resistance	$T_C=25^{\circ}\text{C}$		5		$\text{K}\Omega$
$B_{25/50}$				3375		K

MODULE CHARACTERISTICS

$T_C=25^{\circ}\text{C}$ unless otherwise specified

Symbol	Parameter	Test Conditions	Min.	Typ.	Max.	Unit
$T_{Vj\text{max}}$	Max. Junction Temperature				175	$^{\circ}\text{C}$
$T_{Vj\text{op}}$	Operating Temperature		-40		150	$^{\circ}\text{C}$
T_{stg}	Storage Temperature		-40		125	$^{\circ}\text{C}$
V_{isol}	Insulation Test Voltage	AC, $t=1\text{min}$		3000		V
CTI	Comparative Tracking Index		250			
Torque	Module-to-Sink	Recommended (M5)	2.5		5	$\text{N}\cdot\text{m}$
Torque	Module Electrodes	Recommended (M6)	3		5	$\text{N}\cdot\text{m}$
Weight				350		g

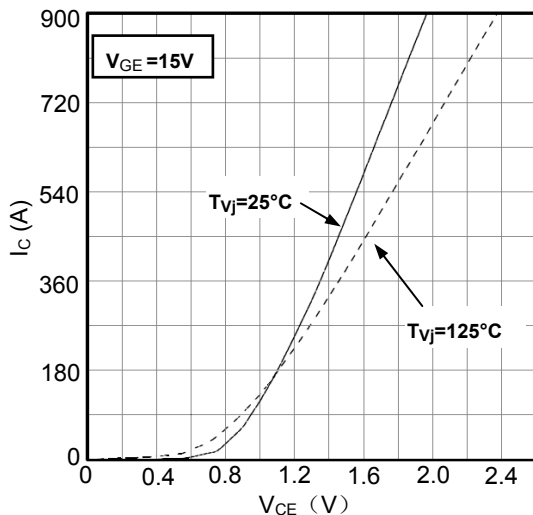

Figure1. Typical Output characteristics IGBT-inverter

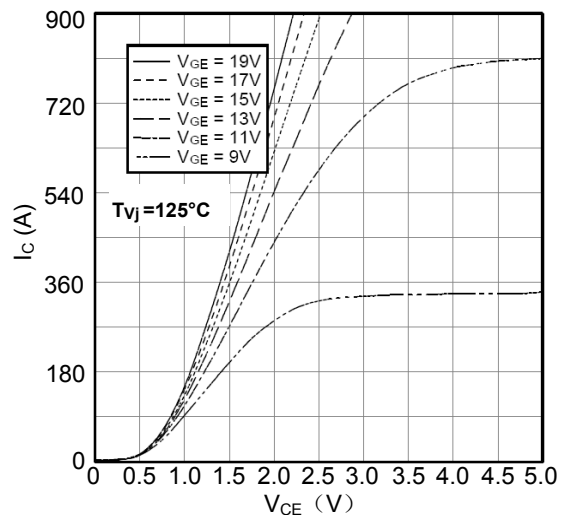

Figure2. Typical Output characteristics IGBT-inverter

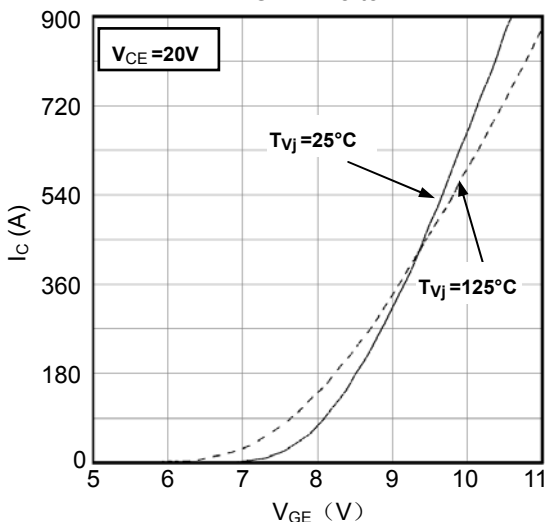

Figure3. Typical Transfer characteristics IGBT-inverter

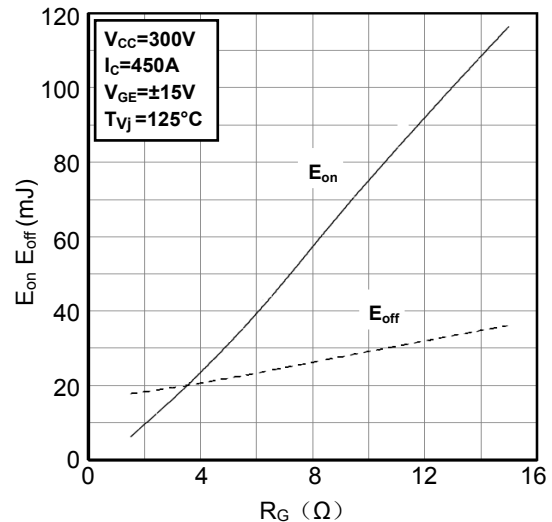

Figure4. Switching Energy vs. Gate Resistor IGBT-inverter

MMG450WB060B6EN

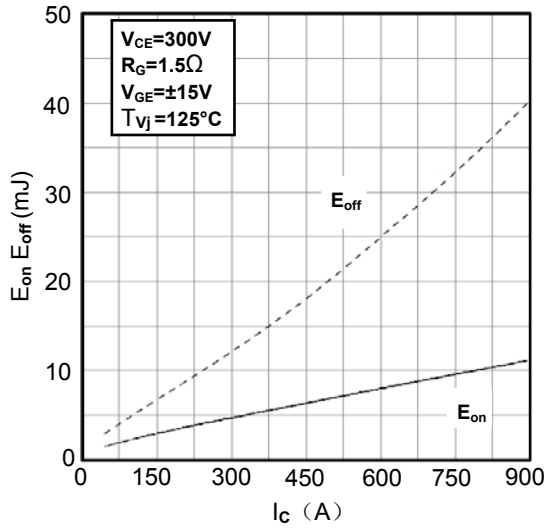

Figure5. Switching Energy vs. Collector Current IGBT-inverter

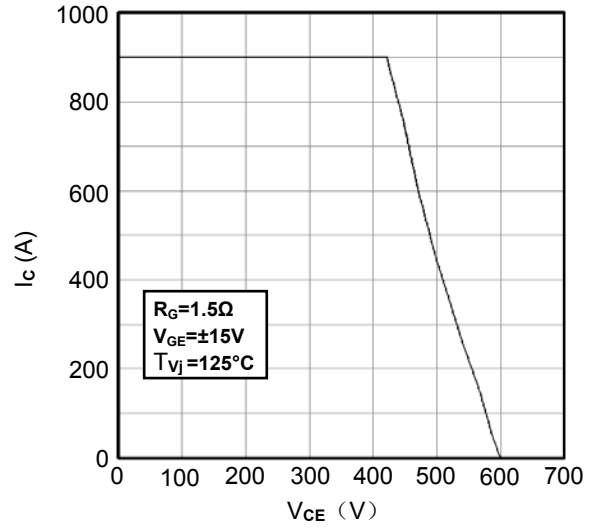

Figure6. Reverse Biased Safe Operating Area IGBT-inverter

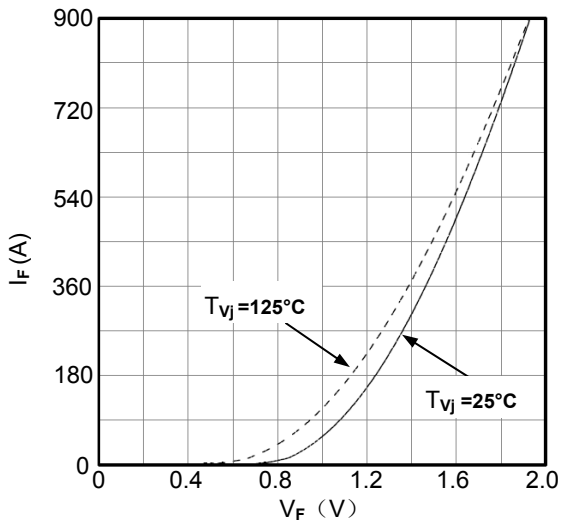

Figure7. Diode Forward Characteristics Diode -inverter

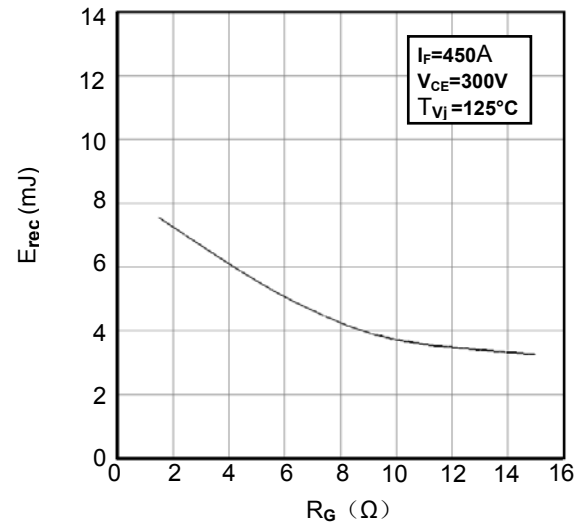

Figure8. Switching Energy vs. Gate Resistor Diode -inverter

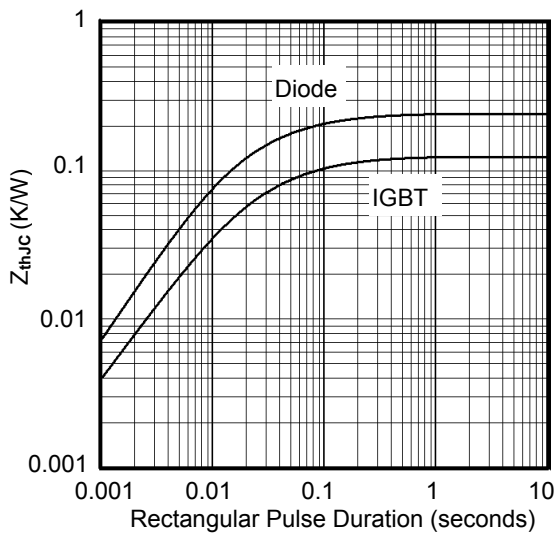

Figure9. Transient Thermal Impedance of Diode and IGBT-inverter

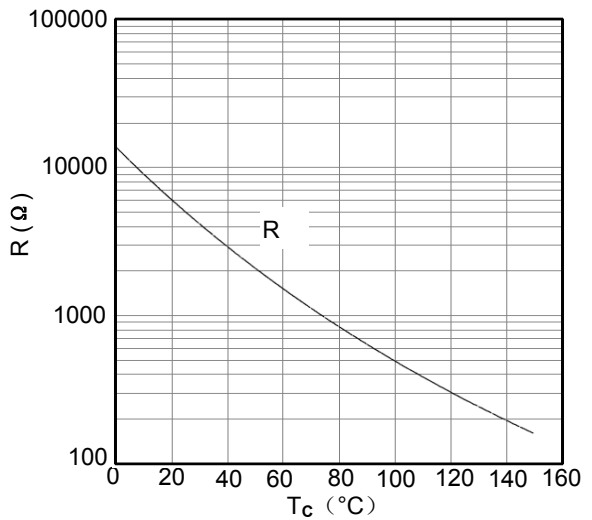

Figure10. NTC Characteristics

MMG450WB060B6EN

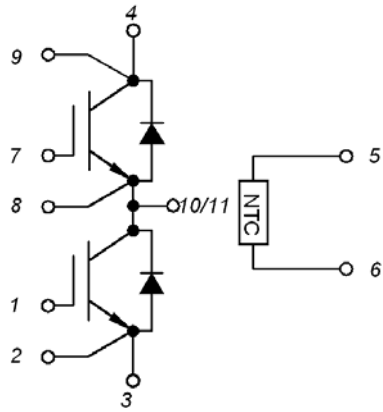
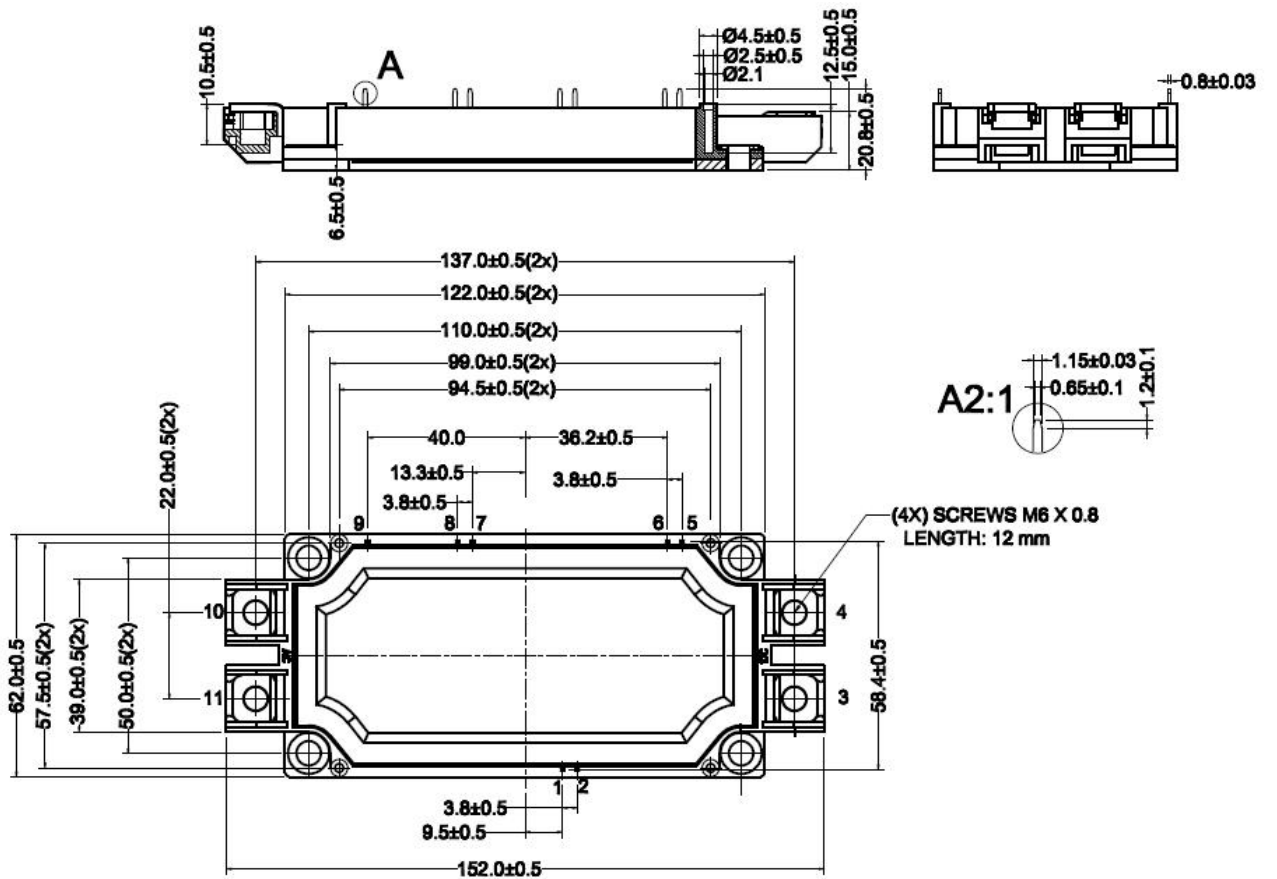

Figure11. Circuit Diagram



Dimensions (mm)
Figure12. Package Outline